

The Harman Kardon Model T45

Manual No. 72A

AUTO-LIFT TURNTABLE

Technical Manual



T45

SPECIFICATIONS

Wow & Flutter (WRMS)	0.04%	Acceptable Weight of Cartridge	3 ~ 8g
Rumble (DIN-B WTD)	-68dB, DIN 45544 record reference	Dimensions (W x H x D)	17-3/8" x 5-3/4" x 14-13/16" (440 x 145 x 375mm)
Pitch Adjustable Range	±3%	Weight	15 lbs. 7 oz. (7kg)
Tonearm		Power Supply	
Effective Tonearm Mass	8g (plus the mass of the cartridge used)	U.S.A. and Canada models	AC120V, 60Hz
Stylus Overhang	18mm	General model	AC110-120V/220-240V, 50/60Hz
Offset Angle	25.5°	Power Consumption	8W
Effective Length	216mm		
Tracking Error	±2 degrees		
Phono Capacitance	160/250/350pF		
Tracking Force	0 ~ 3 grams		

Specifications and components subject to change without notice.
Overall performance will be maintained or improved.

LEAKAGE TEST (FOR SERVICE ENGINEERS IN THE U.S.A.)

Before returning the unit to the user, perform the following safety checks:

1. Inspect all lead dress to make certain that leads are not pinched or that hardware is not lodged between the chassis and other metal parts in the unit.
2. Be sure that any protective devices such as nonmetallic control knobs, insulating fishpapers, cabinet backs, adjustment and compartment covers or shields, isolation resistor-capacity networks, mechanical insulators, etc. which were removed for servicing are properly reinstalled.
3. Be sure that no shock hazard exists; check for leakage current using Simpson Model 229 Leakage Tester, standard equipment item No. 21641, RCA Model WT540A or use alternate method as follows:
Plug the power cord directly into a 120-volt AC receptacle (do not use an Isolation Transformer for this test). Using two clip leads, connect a 1500 Ohm, 10-watt resistor paralleled by a 0.15 μ F capacitor, in series with all exposed metal cabinet parts and a known earth ground, such as a water pipe or conduit. Use a VTVM or VOM with 1000 Ohms per volt, or higher, sensitivity to measure the AC voltage drop across the resistor. (See Diagram.) Move the resistor connection to each exposed metal part having a return path to the chassis (antenna, metal, cabinet, screw heads, knobs and control shafts, escutcheon, etc.) and measure the AC voltage drop across the resistor. (This test should be performed with the power switch in both the On and Off positions.)

A reading of 0.35 volt RMS or more is excessive and indicates a potential shock hazard which must be corrected before returning the unit to the owner.

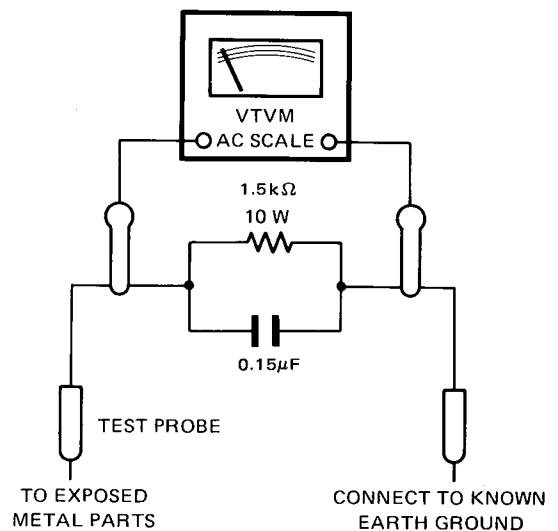
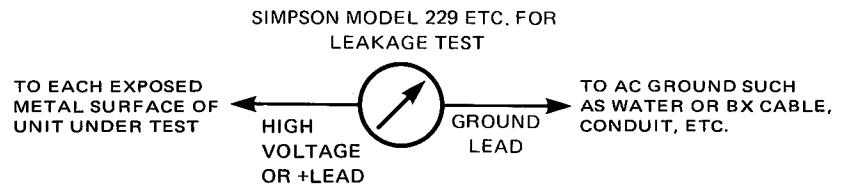

CARTRIDGE REPLACEMENT INSTRUCTION

Only use cartridges in the headshell provided. Be sure to use a cartridge weighting 3 to 8 grams.

1. Release the tonearm clamp and lift the tonearm gently.
2. Loosen the headshell clamp and gently pull the headshell with cartridge. (See Fig. A.)
3. Disconnect the 4 leads from cartridge pins using a tweezers and then loosen the retaining screws so that the cartridge comes out.
4. Replace the leads onto the new cartridge. Refer to Fig. B for correct placement of leads.
5. When all leads are connected properly, install cartridge to the headshell as shown in the Fig. B.
6. Temporarily tighten the retaining screw to hold the cartridge.
7. Insert the headshell with the cartridge fully into the tonearm and then tighten the headshell clamp.

When cartridge is replaced with new one, it is necessary to adjust the Overhang and Tracking angle.

Overhang Adjustment

1. Place the accessory tracking angle gauge on the center spindle and raise the flap.
2. Be sure to remove the stylus guard when adjusting the overhang.
3. Move the tonearm directly over the center spindle. Line up the raised flap on the gauge with the center spindle and the tonearm base. Gently move the cartridge backward or forward in the headshell so that the stylus tip lines up with the corner of the flap.

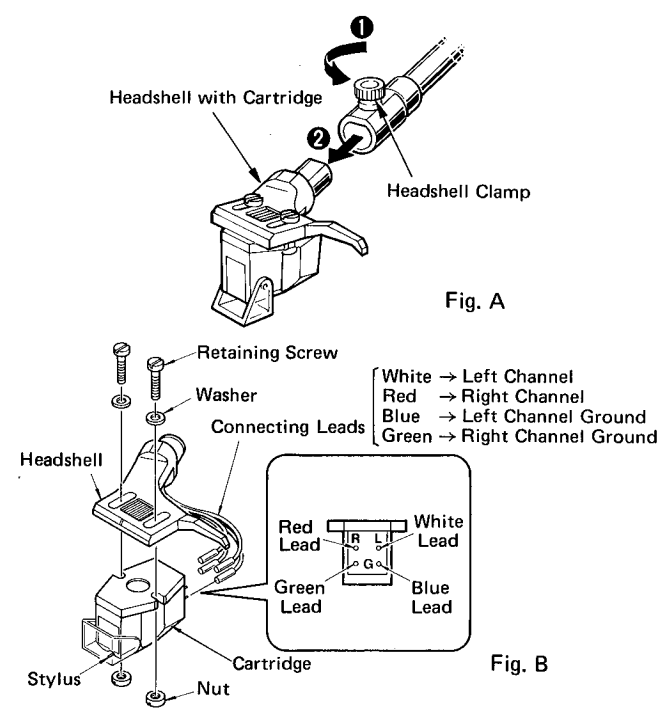

Tracking Angle Adjustment

1. Check to be sure that the overhang adjustment has been completed.
2. Now move the tracking angle gauge until it is in the same position with respect to the tonearm as that shown in Fig. D. Place the stylus over the tracking angle setting point with keeping stylus guard attached.
3. Without changing the stylus position, turn the cartridge so that its front edge is parallel with the lines on the gauge.
4. Now move it so that it is in the position shown in Fig. E and check that the cartridge is still parallel with the parallel lines as it was in step 3 above. If it is not parallel, then repeat steps 3 and 4 alternately until the cartridge is parallel in both cases.
5. When the above adjustment is completed, then tighten the screws that attach the cartridge to the headshell fully.

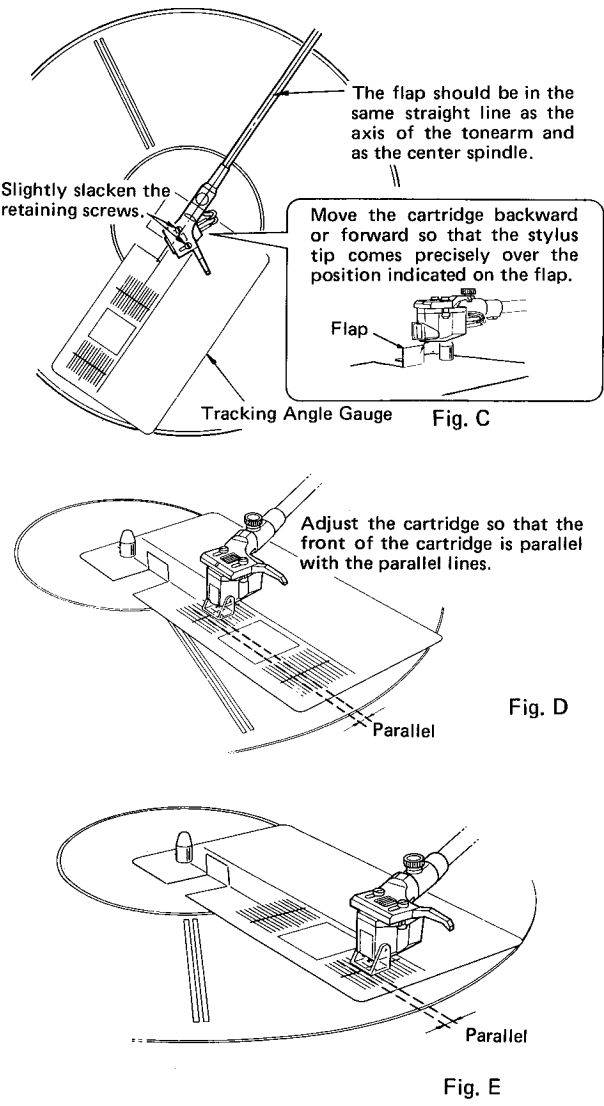

ALIGNMENT PROCEDURES

DISC END DETECTION POSITION ADJUSTMENT

- * Conditions
Be sure not to hang the drive belt between platter and motor pulley.
Lift Switch. Auto

- #### LP POSITION ADJUSTMENT
1. Set the speed selector to the 33 position.
 2. Lower the cue lever. (Raising plate is set to the low position.)
 3. Adjust by adjustment screw attached to the lower part of the tonearm so that the stylus of cartridge detects the disc end position between 111.94 mm ~ 107.2 mm from the center of spindle.

- #### EP POSITION ADJUSTMENT
1. Set the speed selector to the 45 position.
 2. Lower the cue lever. (Raising plate is set to the low position.)
 3. Adjust by adjustment screw attached to the lower part of the tonearm so that the stylus of cartridge detects the disc end position between 102.74 mm ~ 98.4 mm from the center of spindle.

NOTE:

1. Turning the adjustment screw clockwise makes a fast detection of the disc end position, and turning it counterclockwise makes slow detection.
2. If it is not within the rate, assumedly, it results from the attached position of forwarding arm assembly. Try to change the attaching position by loosening the fixing screw.
3. When the disc end position is detected, the tonearm will automatically lift up and the motor revolution will stop. If you are going to start it again, place the tonearm back on armrest.

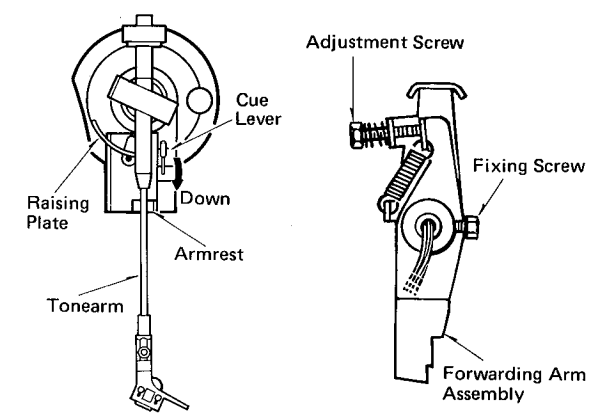

MOTOR R.P.M. ADJUSTMENT

- * Instrument
Low Range Tachometer
- * Conditions
1. Be sure that the drive belt between platter and motor pulley is hung.
2. Flip the cue lever forward to lift the tonearm up.
- When the Speed Reference switch is OFF position.
1. Set the speed selector to the 33 position and set the speed control knob to the center position.
2. Move tonearm horizontally as to be level with the platter, and rotate the platter.
3. With the platter turning, adjust SVR201 so that the motor speed rating is within 33-1/3 r.p.m. ±1%, and then adjust SVR2011 so that the motor speed rating is within 33-1/3 r.p.m.
4. Set the speed selector to the 45 position.
5. With the platter turning, adjust SVR202 so that the motor speed rating is within 45 r.p.m. ±1%, and then adjust SVR2021 so that the motor speed rating is within 45 r.p.m.
- When the Speed Reference switch is ON position.
1. Set the speed selector to the 33 position.
2. Move tonearm horizontally as to be level with the platter, and rotate the platter.
3. Adjust SVR203 by turning the platter so that the motor speed rating is within 33-1/3 r.p.m.
4. Check the motor speed in condition that the speed selector is set to the 45 position.

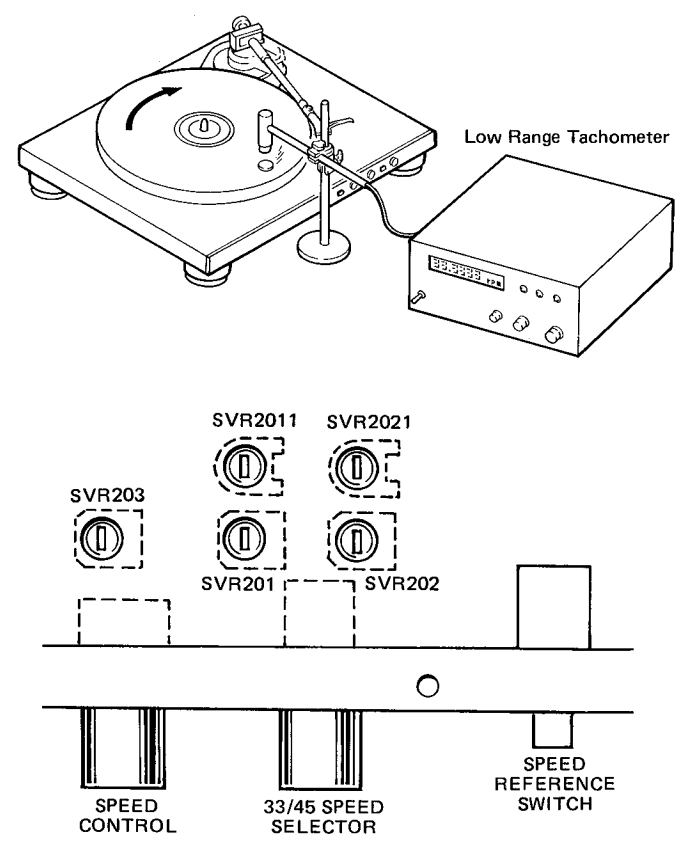

CARTRIDGE REPLACEMENT INSTRUCTION

Only use cartridges in the headshell provided. Be sure to use a cartridge weighting 3 to 8 grams.

1. Release the tonearm clamp and lift the tonearm gently.
2. Loosen the headshell clamp and gently pull the headshell with cartridge. (See Fig. A.)
3. Disconnect the 4 leads from cartridge pins using a tweezers and then loosen the retaining screws so that the cartridge comes out.
4. Replace the leads onto the new cartridge. Refer to Fig. B for correct placement of leads.
5. When all leads are connected properly, install cartridge to the headshell as shown in the Fig. B.
6. Temporarily tighten the retaining screw to hold the cartridge.
7. Insert the headshell with the cartridge fully into the tonearm and then tighten the headshell clamp.

When cartridge is replaced with new one, it is necessary to adjust the Overhang and Tracking angle.

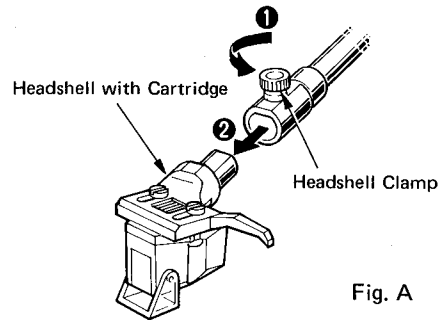

Fig. A

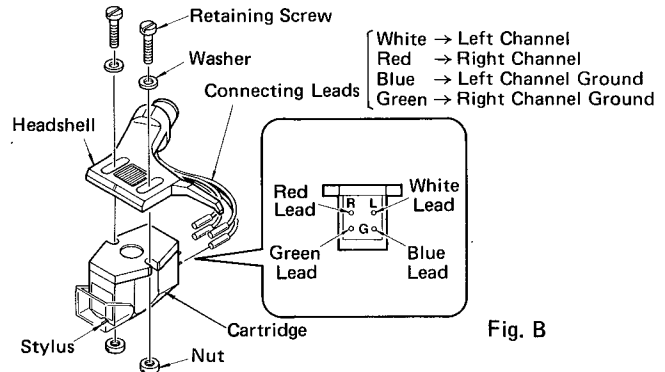

Fig. B

● Overhang Adjustment

1. Place the accessory tracking angle gauge on the center spindle and raise the flap.
2. Be sure to remove the stylus guard when adjusting the overhang.
3. Move the tonearm directly over the center spindle. Line up the raised flap on the gauge with the center spindle and the tonearm base. Gently move the cartridge backward or forward in the headshell so that the stylus tip lines up with the corner of the flap.

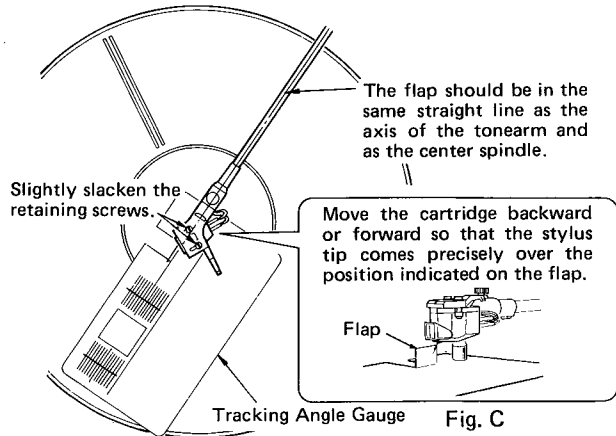

Fig. C

● Tracking Angle Adjustment

1. Check to be sure that the overhang adjustment has been completed.
2. Now move the tracking angle gauge until it is in the same position with respect to the tonearm as that shown in Fig. D. Place the stylus over the tracking angle setting point with keeping stylus guard attached.
3. Without changing the stylus position, turn the cartridge so that its front edge is parallel with the lines on the gauge.
4. Now move it so that it is in the position shown in Fig. E and check that the cartridge is still parallel with the parallel lines as it was in step 3 above. If it is not parallel, then repeat steps 3 and 4 alternately until the cartridge is parallel in both cases.
5. When the above adjustment is completed, then tighten the screws that attach the cartridge to the headshell fully.

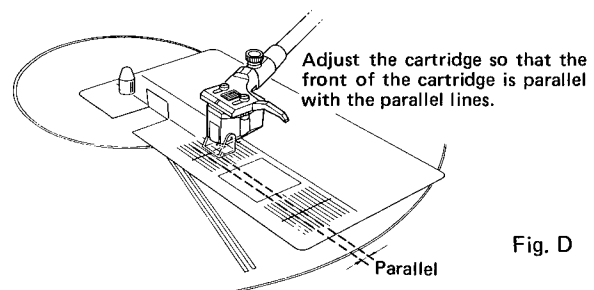

Fig. D

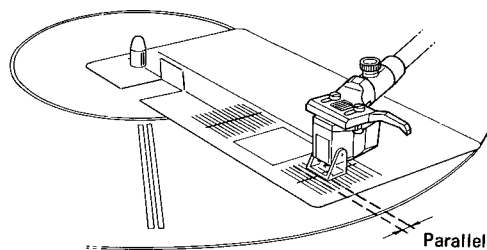

Fig. E

ALIGNMENT PROCEDURES

■ DISC END DETECTION POSITION ADJUSTMENT

*** Conditions**

Be sure not to hang the drive belt between platter and motor pulley.

Lift Switch. Auto

● **LP POSITION ADJUSTMENT**

1. Set the speed selector to the 33 position.
2. Lower the cue lever. (Raising plate is set to the low position.)
3. Adjust by adjustment screw attached to the lower part of the tonearm so that the stylus of cartridge detects the disc end position between 111.94 mm ~ 107.2 mm from the center of spindle.

● **EP POSITION ADJUSTMENT**

1. Set the speed selector to the 45 position.
2. Lower the cue lever. (Raising plate is set to the low position.)
3. Adjust by adjustment screw attached to the lower part of the tonearm so that the stylus of cartridge detects the disc end position between 102.74 mm ~ 98.4 mm from the center of spindle.

NOTE:

1. Turning the adjustment screw clockwise makes a fast detection of the disc end position, and turning it counterclockwise makes slow detection.
2. If it is not within the rate, assumedly, it results from the attached position of forwarding arm assembly. Try to change the attaching position by loosening the fixing screw.
3. When the disc end position is detected, the tonearm will automatically lift up and the motor revolution will stop. If you are going to start it again, place the tonearm back on armrest.

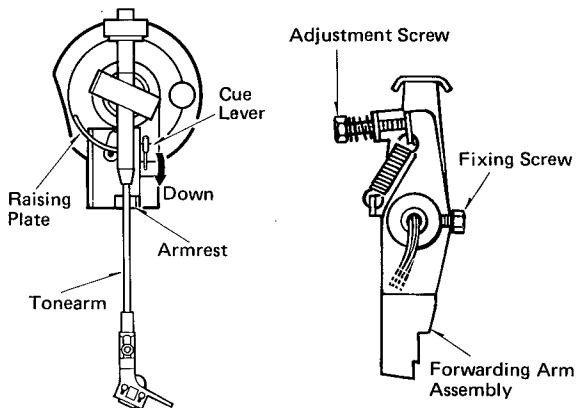

■ MOTOR R.P.M. ADJUSTMENT

*** Instrument**

Low Range Tachometer

*** Conditions**

1. Be sure that the drive belt between platter and motor pulley is hung.
2. Flip the cue lever forward to lift the tonearm up.

● **When the Speed Reference switch is OFF position.**

1. Set the speed selector to the 33 position and set the speed control knob to the center position.
2. Move tonearm horizontally as to be level with the platter, and rotate the platter.
3. With the platter turning, adjust SVR201 so that the motor speed rating is within 33-1/3 r.p.m. ±1%, and then adjust SVR2011 so that the motor speed rating is within 33-1/3 r.p.m.
4. Set the speed selector to the 45 position.
5. With the platter turning, adjust SVR202 so that the motor speed rating is within 45 r.p.m. ±1%, and then adjust SVR2021 so that the motor speed rating is within 45 r.p.m.

● **When the Speed Reference switch is ON position.**

1. Set the speed selector to the 33 position.
2. Move tonearm horizontally as to be level with the platter, and rotate the platter.
3. Adjust SVR203 by turning the platter so that the motor speed rating is within 33-1/3 r.p.m.
4. Check the motor speed in condition that the speed selector is set to the 45 position.

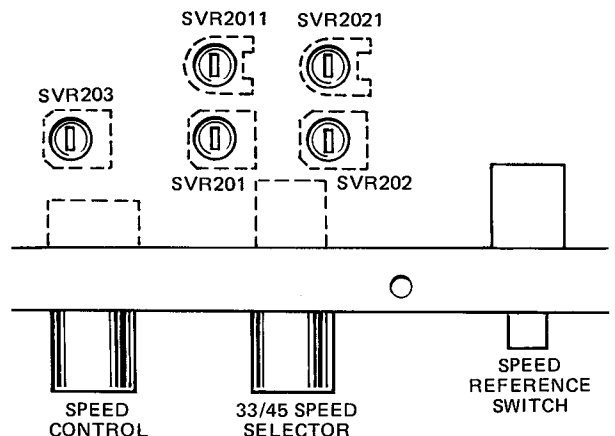
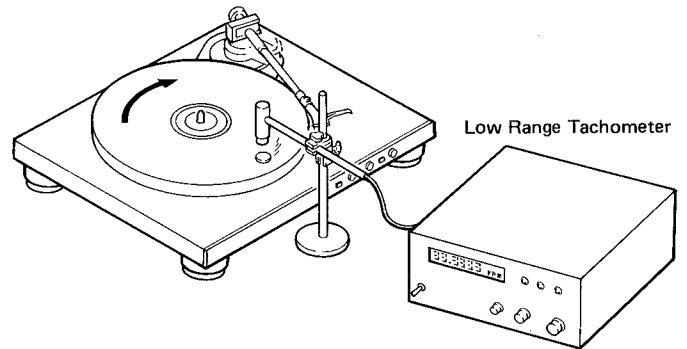

DISASSEMBLY PROCEDURES (REFER TO PAGES 6 AND 11)

1 MAIN P.C. BOARD (PCB-1) REMOVAL

1. Remove 5 screws **A** and remove the Bottom Cover B (31).
2. Remove 2 screws **B** and remove the Main P.C. Board (PCB-1) with Bracket (41) and LED P.C. Board (PCB-3). If necessary, unsolder the lead wires.

2 FRONT PANEL ASSEMBLY (2) REMOVAL

1. Remove the Main P.C. Board (PCB-1). (Refer to step 1.)
2. Remove 3 screws **C** mounting Front Panel Assembly (2) and remove it.

3 MOTOR ASSEMBLY (MO1) REMOVAL

1. Remove 5 screws **D** and 2 hexagon nuts **E** and remove the Bottom Cover A (22) with Power Transformer (T1).
2. Remove 2 hexagon nuts **F** and remove the Motor Assembly (MO1) with the Motor Bracket (19). If necessary, unsolder the lead wires.

4 POWER TRANSFORMER (T1) REMOVAL

1. Remove the Bottom Cover A (22). (Refer to step 3-1.)
2. Remove 2 screws **G** and remove the Power Transformer (T1).

5 PICK-UP ASSEMBLY (3) REMOVAL

1. Remove 6 screws **H** and remove Bottom Cover C (32).
2. Unsolder the pick-up leads from Relay P.C. Board.
3. Loosen the fixing screw **I** of the Forwarding Arm Assembly (13).
4. Remove the screw **J** on the Pick-Up Base Assembly (4) and then pull out Pick-Up Assembly (3) upward from Pick-Up Base Assembly (4).

6 PICK-UP BASE ASSEMBLY (4) REMOVAL

1. Remove the Pick-Up Assembly (3). (Refer to step 5.)
2. Remove 2 screws **K** and remove the Micro Switch (SW1).
3. Remove 2 screws **L** and remove the Sensor Assembly (SE1).
4. Remove 4 screws **M** and remove the Pick-Up Base Assembly (4).

POWER CORD REPLACEMENT (FOR SERVICE ENGINEERS OTHER THAN NORTH AMERICA)

In order to prevent fire or shock hazard when replacing the power cord, follow the procedure below to replace the parts with the standard supply parts.

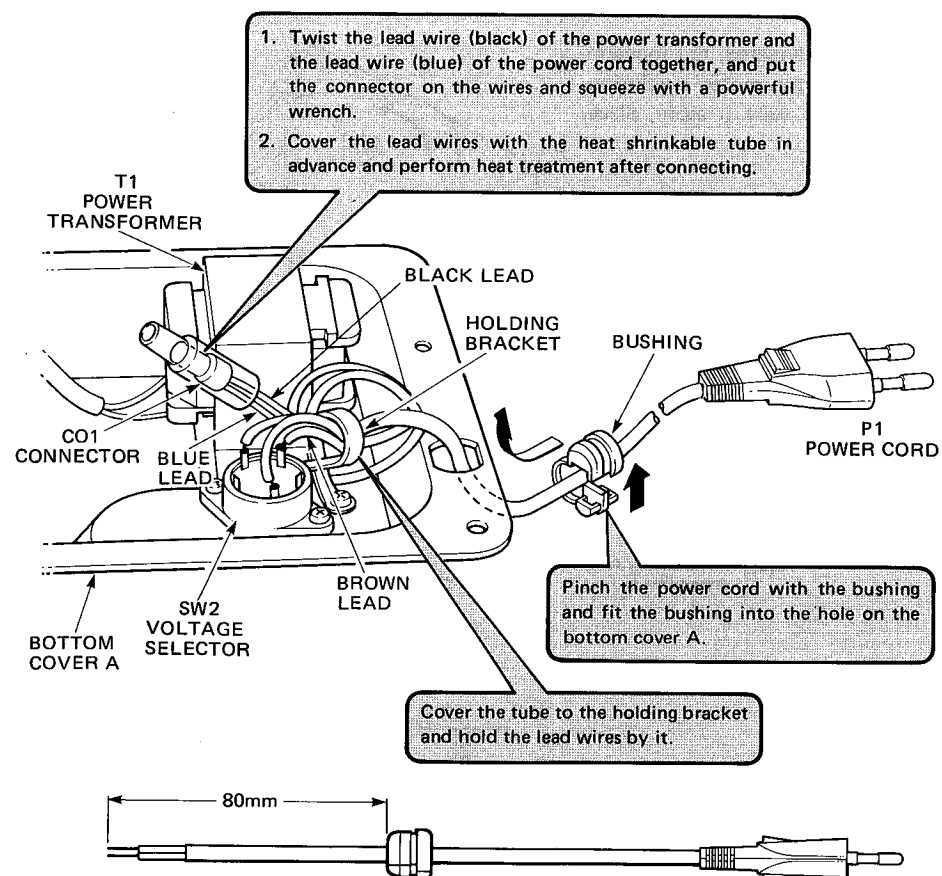

GENERAL UNIT EXPLODED VIEW

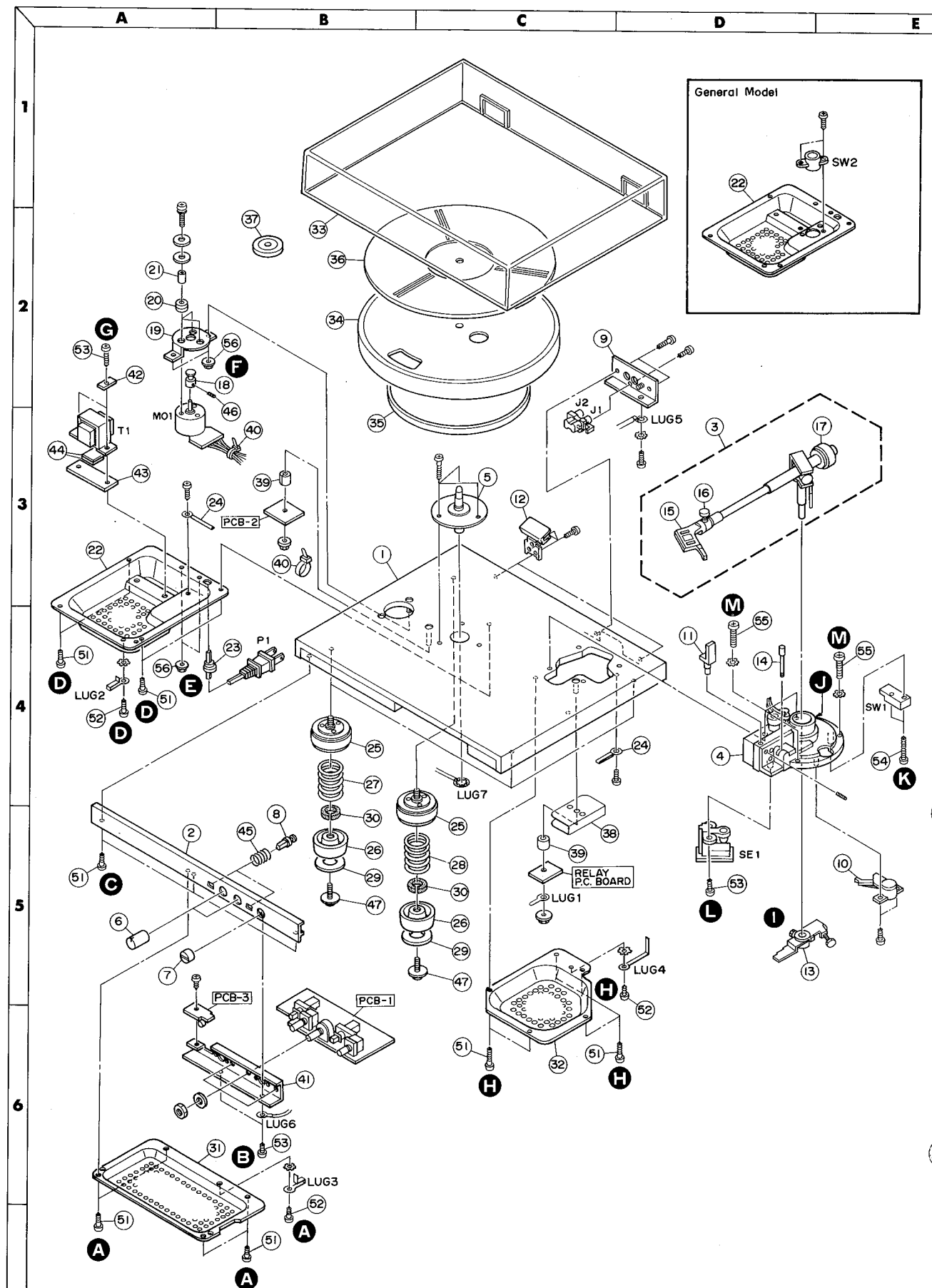

DISASSEMBLY PROCEDURES (REFER TO PAGES 6 AND 11)

1 MAIN P.C. BOARD (PCB-1) REMOVAL

1. Remove 5 screws **A** and remove the Bottom Cover B (31).
2. Remove 2 screws **B** and remove the Main P.C. Board (PCB-1) with Bracket (41) and LED P.C. Board (PCB-3). If necessary, unsolder the lead wires.

2 FRONT PANEL ASSEMBLY (2) REMOVAL

1. Remove the Main P.C. Board (PCB-1). (Refer to step 1.)
2. Remove 3 screws **C** mounting Front Panel Assembly (2) and remove it.

3 MOTOR ASSEMBLY (MO1) REMOVAL

1. Remove 5 screws **D** and 2 hexagon nuts **E** and remove the Bottom Cover A (22) with Power Transformer (T1).
2. Remove 2 hexagon nuts **F** and remove the Motor Assembly (MO1) with the Motor Bracket (19). If necessary, unsolder the lead wires.

4 POWER TRANSFORMER (T1) REMOVAL

1. Remove the Bottom Cover A (22). (Refer to step 3-1.)
2. Remove 2 screws **G** and remove the Power Transformer (T1).

5 PICK-UP ASSEMBLY (3) REMOVAL

1. Remove 6 screws **H** and remove Bottom Cover C (32).
2. Unsolder the pick-up leads from Relay P.C. Board.
3. Loosen the fixing screw **I** of the Forwarding Arm Assembly (13).
4. Remove the screw **J** on the Pick-Up Base Assembly (4) and then pull out Pick-Up Assembly (3) upward from Pick-Up Base Assembly (4).

6 PICK-UP BASE ASSEMBLY (4) REMOVAL

1. Remove the Pick-Up Assembly (3). (Refer to step 5.)
2. Remove 2 screws **K** and remove the Micro Switch (SW1).
3. Remove 2 screws **L** and remove the Sensor Assembly (SE1).
4. Remove 4 screws **M** and remove the Pick-Up Base Assembly (4).

POWER CORD REPLACEMENT (FOR SERVICE ENGINEERS OTHER THAN NORTH AMERICA)

In order to prevent fire or shock hazard when replacing the power cord, follow the procedure below to replace the parts with the standard supply parts.

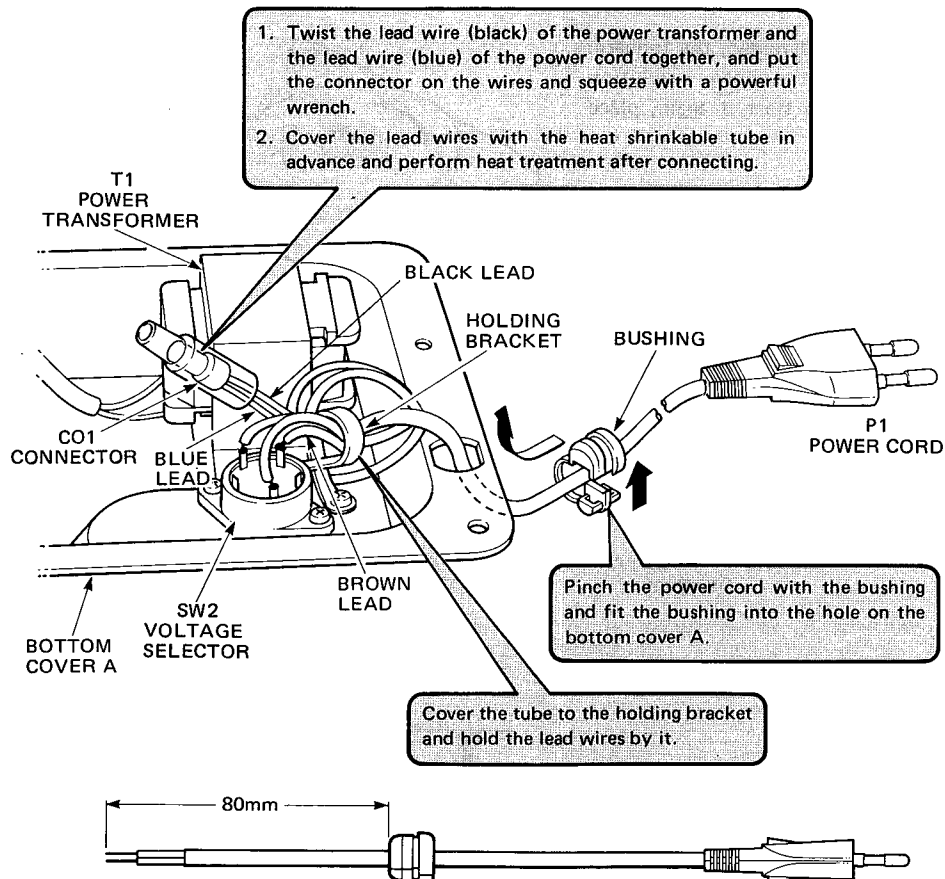

GENERAL UNIT EXPLODED VIEW

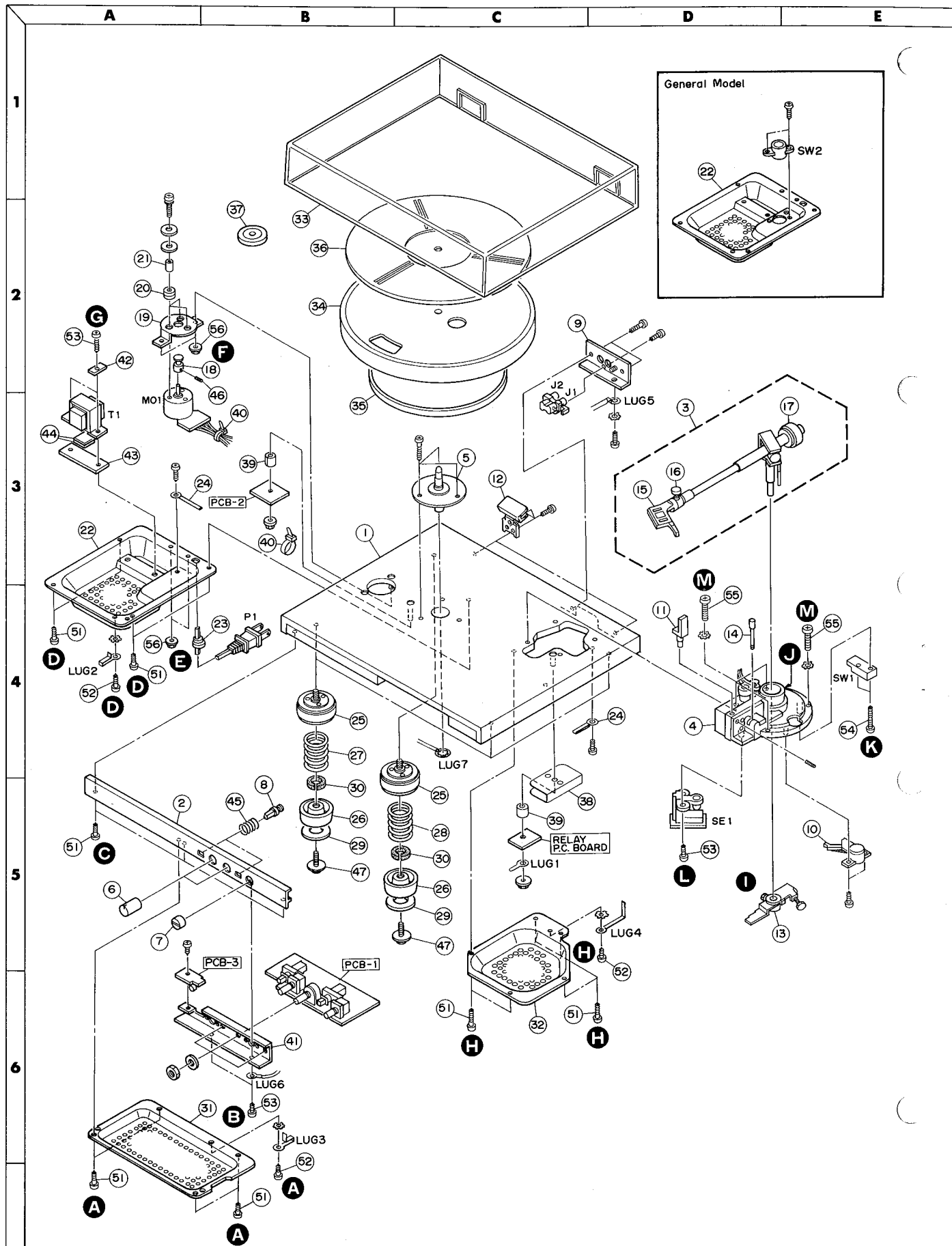

GENERAL UNIT PARTS LIST

Ref. No.	Part No.	Description
1	A415-T45A	Cabinet Assembly (for U.S.A. and Canada models)
	A415-T45B	Cabinet Assembly (for General model)
2	A443-T45	Front Panel Assembly
3	A371-T35	Pick-Up Assembly (without Cartridge and Stylus)
4	A562-T35	Pick-Up Base Assembly
5	2601-7108	Center Spindle Assembly
6	A634-T35A	Knob Assembly, 33/45 Speed Selector, Speed Control
7	A634-T45	Knob Assembly, Cap. Trim
8	A660-T35	Push Button Assembly, Speed Reference, Lift
9	A724-T45	Terminal Plate Assembly
10	A634-T35B	Anti-Skating Control Assembly
11	912285	Armrest Assembly
12	910557-1	Hinge Assembly
13	911451-1	Forwarding Arm Assembly
14	912200	Cue Lever
15	852366S	Headshell
16	852366A	Headshell Clamp
17	852366W	Counterweight
18	894021	Motor Pulley
19	912205	Motor Bracket
20	242020	Bushing
21	915204	Sleeve
22	853236	Bottom Cover A (for U.S.A. and Canada models)
	853236-1	Bottom Cover A (for General model)
23	891568-5	Bushing
24	890755	Holding Bracket
25	914901-1	Foot
26	914902	Foot
27	914960	Spring
28	914960-1	Spring
29	914961	Felt
30	914994	Absorber
31	873952	Bottom Cover B
32	873953	Bottom Cover C
33	852682	Dust Cover
34	620107	Platter
35	700515B	Drive Belt
36	2115-00101	Platter Mat
37	912286	45 RPM Adaptor
38	890959-1	Shield Plate
39	897342-1	Spacer
40	894408	Holder, Lead Wire
41	873949	Bracket
42	915132	Bracket
43	915121	Bracket
44	915122	Plate
45	2651-210189	Spring
46	Y13200301	Screw (-) (2 x 3mm)
47	912290	Foot Screw
51	Y08301207	Self-Tapping Screw (+) (3 x 12mm)
52	Y10300601	Screw (+) (3 x 6mm)
53	Y10300801	Screw (+) (3 x 8mm)
54	Y10262001	Screw (+) (2.6 x 20mm)
55	Y03301802	Screw (+) (3 x 18mm)
56	Y22000302	Hexagon Nut

ELECTRICAL PARTS LIST

Ref. No.	Part No.	Description
CHASSIS MISCELLANEOUS		
△ P1	892435	Power Cord (for U.S.A. and Canada models)
△ P1	895617-2	Power Cord (for General model)
△ T1	873950-1	Power Transformer (for U.S.A. and Canada models)
△ T1	873982	Power Transformer (for General model)
△ CO1, 2	9131421	Connector, Power Cord
SW1	895430-1	Micro Switch, Rest
△ SW2	898256-5	Rotary Switch, Voltage Selector (General model only)
MO1	707718002	Motor Assembly
SE1	D551-T35	Senser Assembly, Auto-Lift
L1	N.A. Separately	Solenoid, Auto-Lift (Part of Pick-Up Base Assembly)
J1/2	913924	2-Pin Jack, Output
LUG1	911872	Lug Terminal
LUG2, 3, 4	915205	Lug Terminal
LUG5	914359-6	Lug Terminal with Lead Wire
LUG6	914359-8	Lug Terminal with Lead Wire
LUG7	914365	Lug Terminal with Lead Wire
PCB-1 MAIN P.C. BOARD		
RESISTORS		
R212	Z4054030A	270Ω, ±5%, 1W, Metal
CONTROLS		
VR201	910746-2	Variable Resistor, 5kΩB, Speed Control
SVR201	Z4060071	Semi-Variable Resistor, 50kΩB
SVR202	Z4060018	Semi-Variable Resistor, 20kΩB
SVR203	Z4060017	Semi-Variable Resistor, 5kΩB
SVR2011, 2021	Z4060070	Semi-Variable Resistor, 2kΩB
CAPACITORS		
C201	5345-108-35	1000μF, ±20%, 35V, Electrolytic
C202	5345-475-50	4.7μF, ±20%, 50V, Electrolytic
C205	5345-477-25	470μF, ±20%, 25V, Electrolytic
C206	5345-225-50	2.2μF, ±20%, 50V, Electrolytic
C207	5345-476-25	47μF, ±20%, 25V, Electrolytic
C208	5345-475D0951	4.7μF, ±20%, 25V, Electrolytic
TRANSISTORS		
X201, 202, 204, 205	Z4104103	2SC945(Q) or 2SC945(P) or 2SC945(K)
X203	Z4106132	2SD882(P)
DIODES		
D201	Z4110011	F14A
D202, 203	Z4110111	1S953
ZD201	Z4112112	Zener, RD12EB3
MISCELLANEOUS		
SCR201	Z4115021	Silicon Controlled Rectifier, 03P05M
SW201	873405-2	Rotary Switch, Cap. Trim
SW202	873404-1	Rotary Switch, 33/45 Speed Selector
SW203, 204	911590-1	Push Switch, Speed Reference, Lift
PCB-2 POWER SUPPLY P.C. BOARD		
△ D204	Z4110041	Bridge Silicon Diode, S1VB10
△ FU201	704395-5	Fuse, 1.25A 250V (for U.S.A. and Canada models)
△ FU201	893791-3	Fuse, T800mA 250V (for General model)
CNP1	706033-2	Connector, 2 Pos.
△	893395-1	Fuse Holder (for U.S.A. and Canada models)
△	893395	Fuse Holder (for General model)
PCB-3 LED P.C. BOARD		
LED1	873409	L.E.D., GL2PR1, Speed Reference Indicator

⚠ SAFETY RELATED COMPONENT. USE ONLY EXACT REPLACEMENT PART AS SPECIFIED

PACKAGE

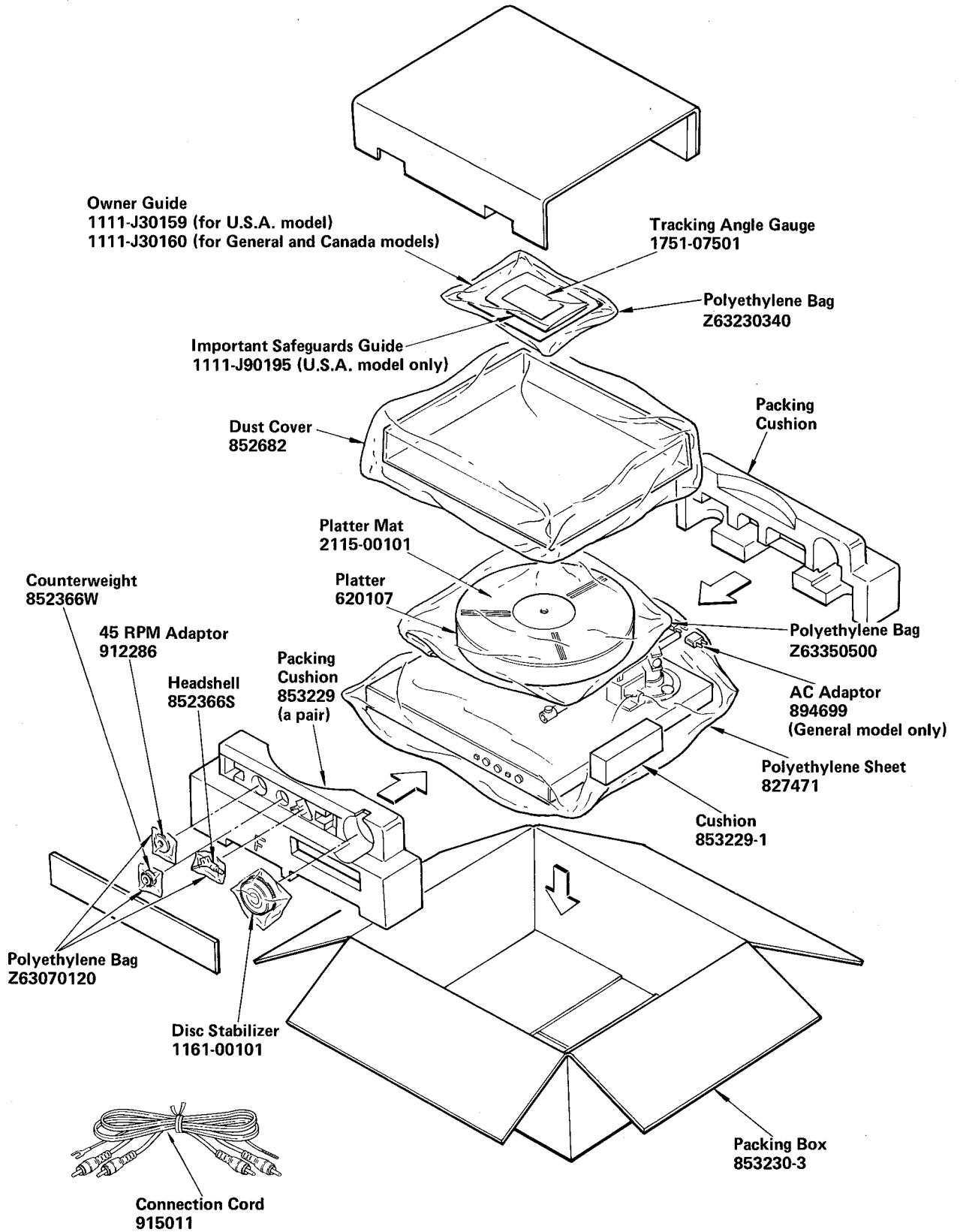

SCHEMATIC DIAGRAM

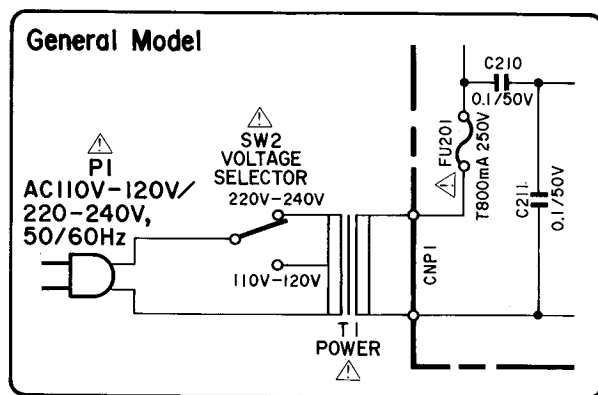

PICK-UP ASSEMBLY

RELAY P.C. BOARD

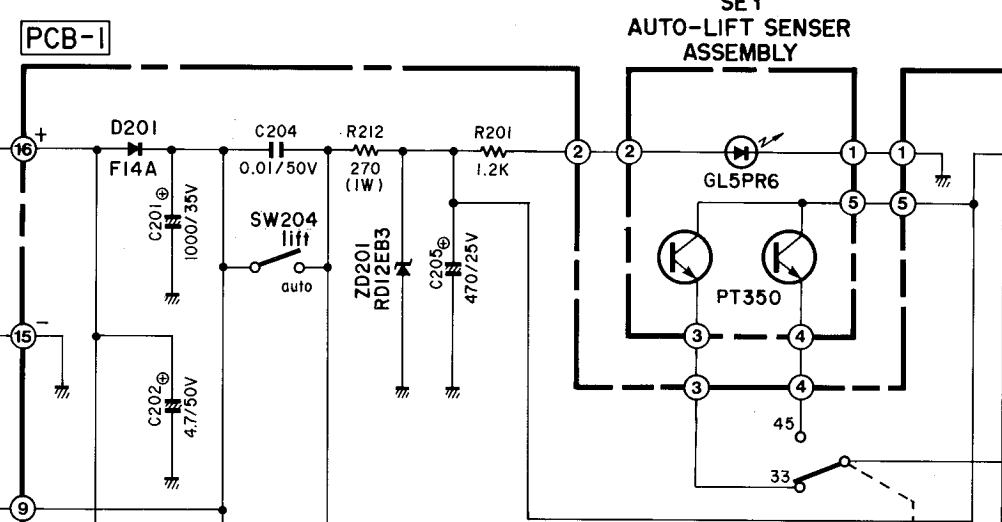
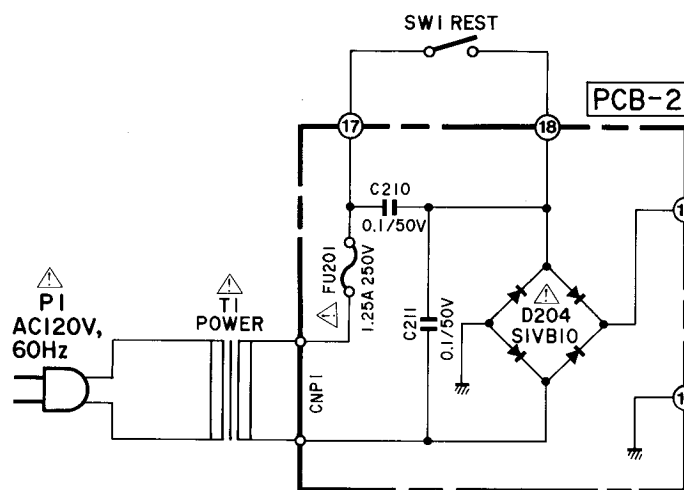
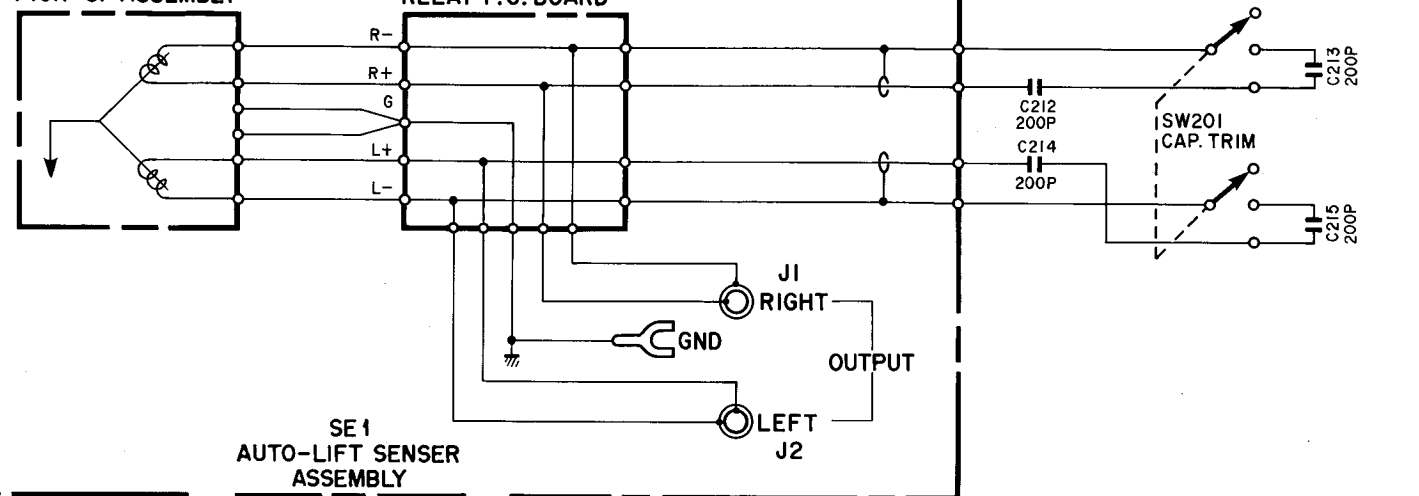

MO1 MOTOR ASSEMBLY

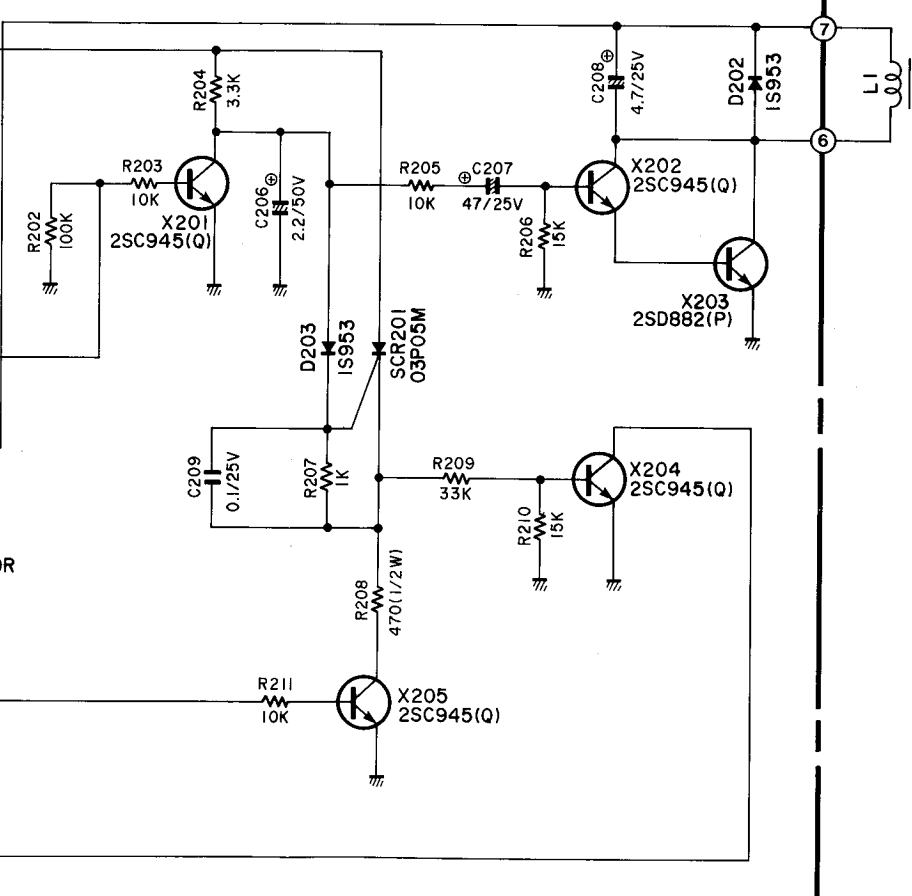
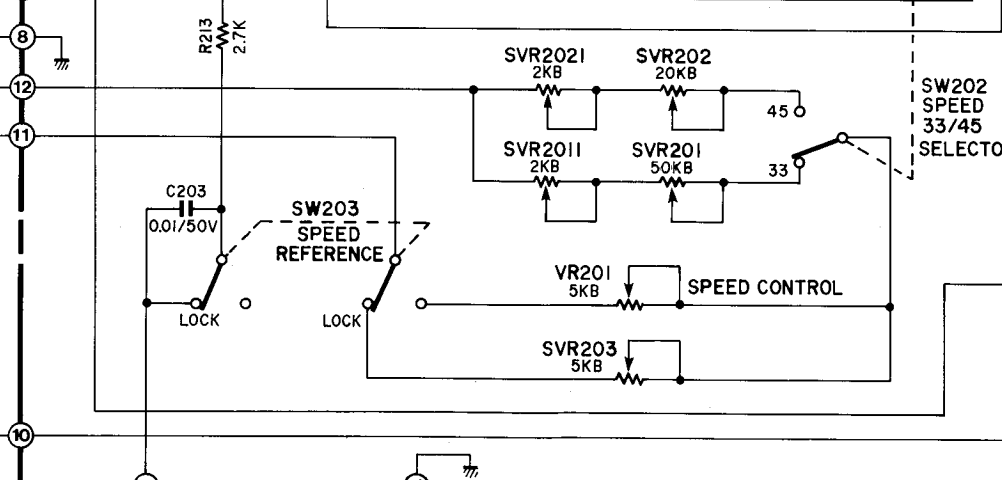
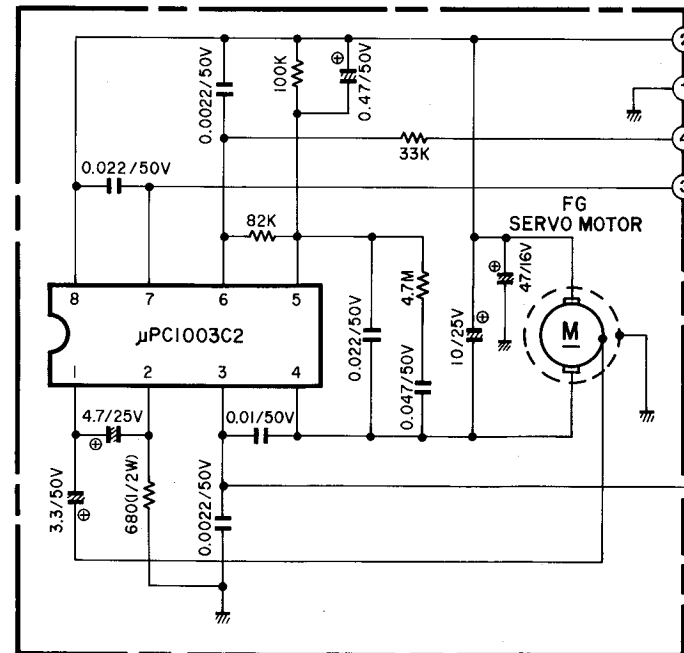

PCB-3



1. ALL RESISTANCES VALUES ARE IN Ω.
kΩ= 1000Ω, MΩ= 1000kΩ
2. THE WATTAGE OF RESISTORS IS 1/4W UNLESS OTHERWISE NOTED.
3. ALL CAPACITANCES VALUES ARE IN µF UNLESS OTHERWISE NOTED. P = µµF
4. SAFETY-REQUIREMENTS COMPONENTS IN ACCORDANCE WITH PRESENT SAFETY REGULATIONS, THESE COMPONENTS MUST ONLY BE REPLACED BY ORIGINAL PARTS.

A

B

C

D

E

SCHEMATIC DIAGRAM

General Model

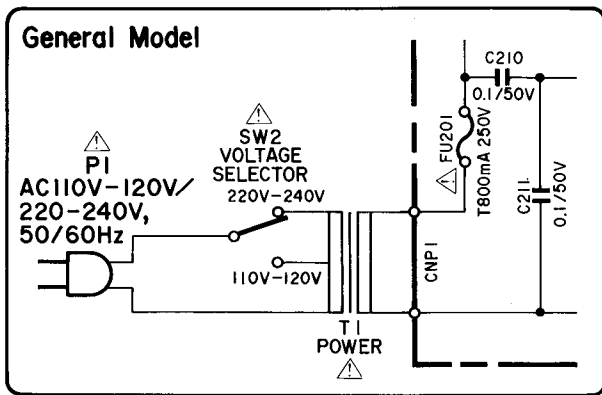

PICK-UP ASSEMBLY

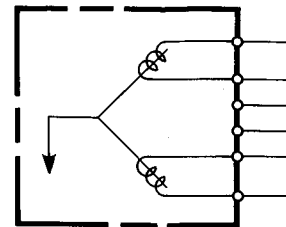

SW1 REST

PCB-2

PCB-1

AUTO

P1 AC120V, 60Hz

T1 POWER

CN P1

FU201 1.25A 250V

C210 0.1/50V

C211 0.1/50V

D204 SIVB10

D201 F14A

C204 0.01/50V

R212 270 (1W)

R201 1.2K

C201 1000/35V

C202 4.7/50V

SW204 lift auto

ZD201 RD12EB3

C205 470/25V

MO1 MOTOR ASSEMBLY

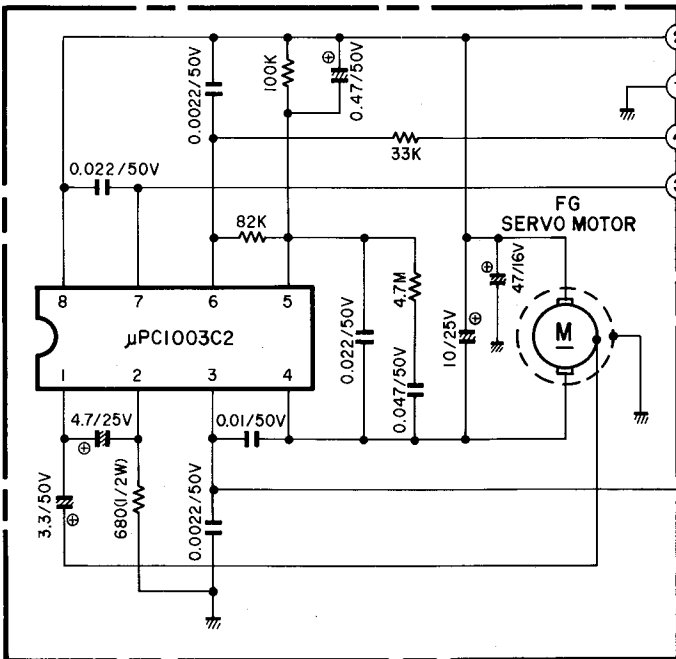

C203 0.01/50V

SW203 SPEED REFERENCE

R213 2.7K

LOCK

LOCK

SVR201 2KB

SVR202 20K

SVR201 2KB

SVR202 50K

VR201 5KB

SVR203 5KB

PCB-3

LED1

GL2PRI

1

2

3

4

5

6

7

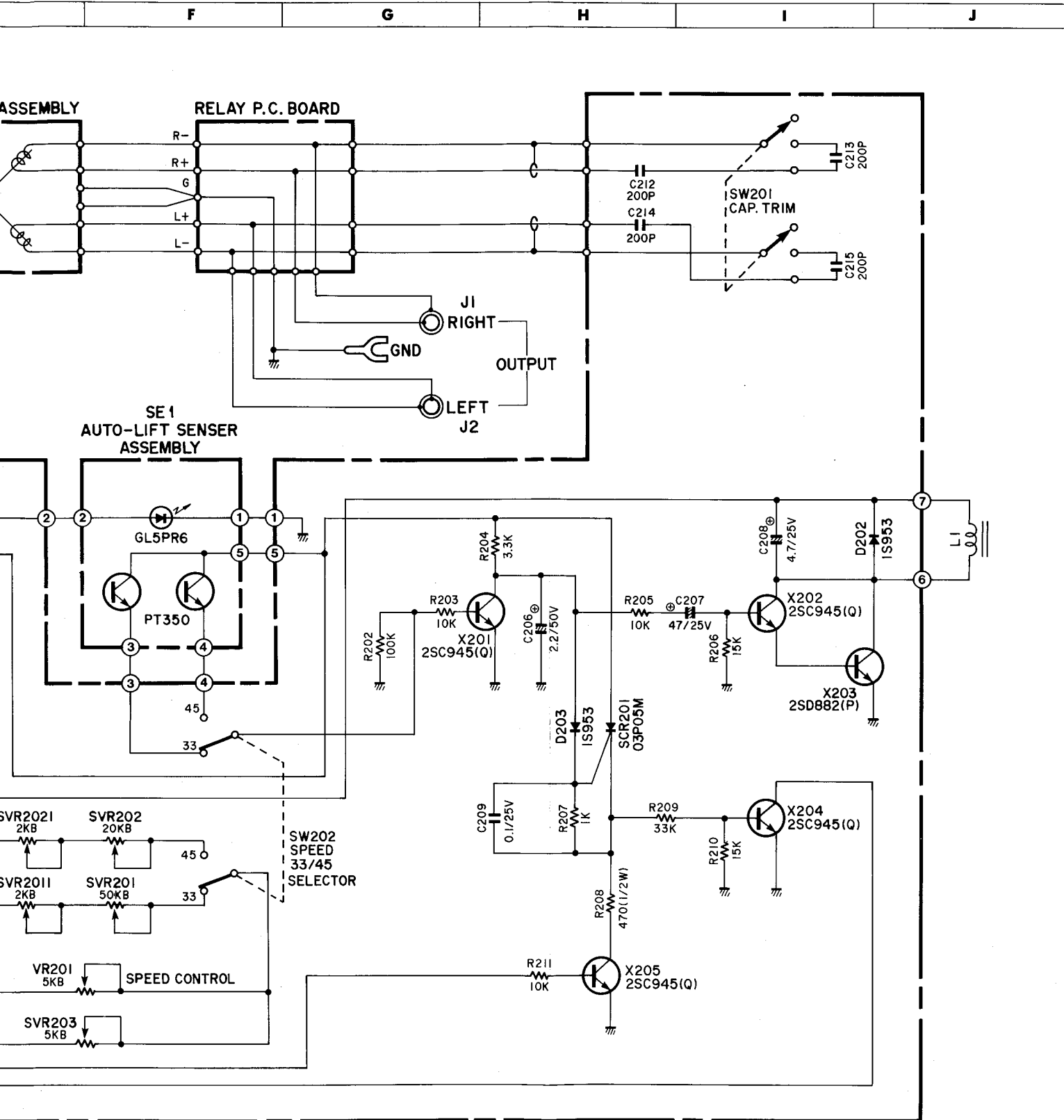

1. ALL RESISTANCES VALUES ARE IN Ω .
 $k\Omega = 1000\Omega$, $M\Omega = 1000k\Omega$
2. THE WATTAGE OF RESISTORS IS 1/4W UNLESS OTHERWISE NOTED.
3. ALL CAPACITANCES VALUES ARE IN μF UNLESS OTHERWISE NOTED. P = $\mu\mu F$
4. SAFETY-REQUIREMENTS COMPONENTS IN ACCORDANCE WITH PRESENT SAFETY REGULATIONS, THESE COMPONENTS MUST ONLY BE REPLACED BY ORIGINAL PARTS.



WIRING DIAGRAM

General Model

1

2

3

4

5

6

7

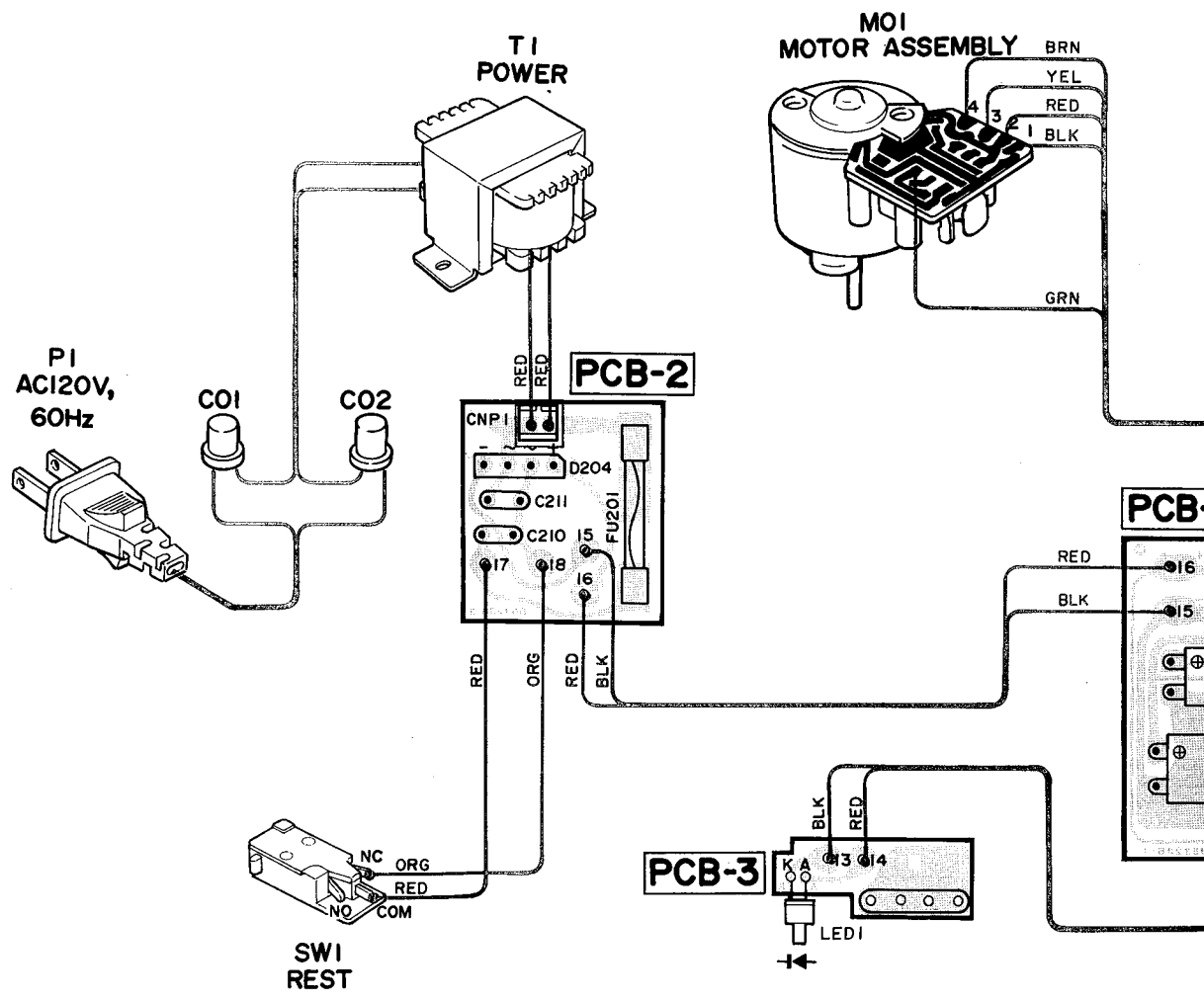
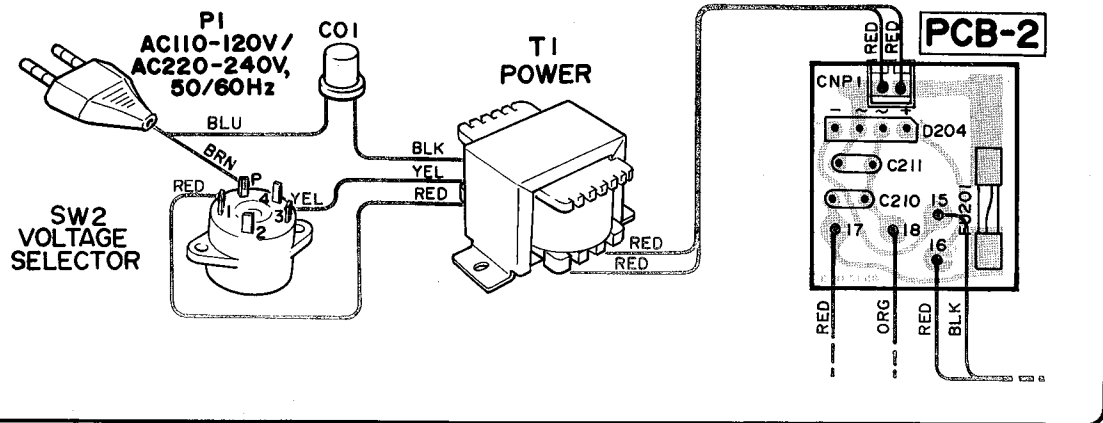

PIN CONNECTION DIAGRAM OF TRANSISTORS AND DIODES.

<p>2SC945(Q) or (P) or (K)</p>	<p>2SD882(P)</p>	<p>SE1 GL5PR6</p>	<p>PT350</p>	<p>F14A</p>	<p>1S953, RD12EB3</p>	<p>S1VB10</p>
--------------------------------	------------------	-----------------------	--------------	-------------	-----------------------	---------------

**SEI
AUTO-LIFT
SENER ASSEMBLY**

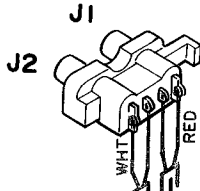
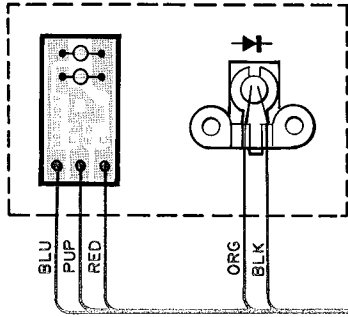

PICK-UP ASSEMBLY

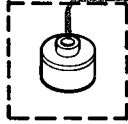

**RELAY
P.C. BOARD**

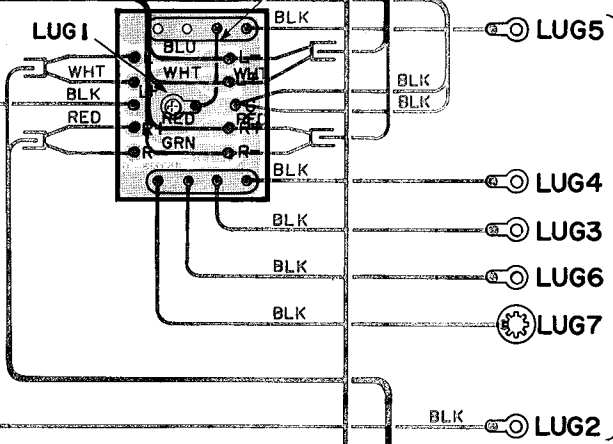

Refer to page 6

LI SOLENOID

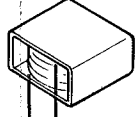

B-1

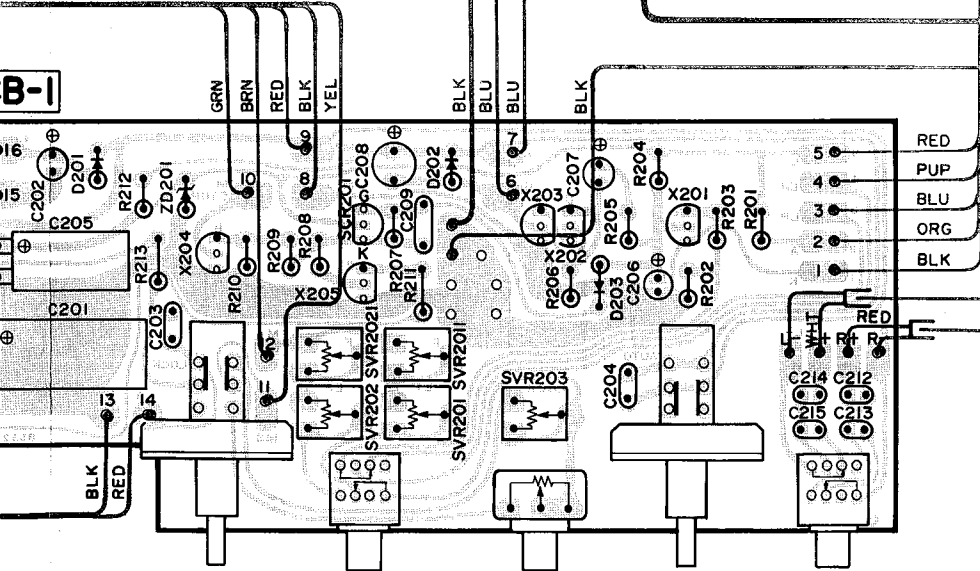

- SW203** REFERENCE
- SW202** 33/45
- VR201** Control
- SW204** manual lift
- SW201** CAP. TRIM

• WIRE COLOR ABBREVIATIONS

- RED : Red
- ORG : Orange
- BLU : Blue
- WHT : White
- GRN : Green
- BLK : Black
- YEL : Yellow
- PUP : Purple
- PIK : Pink

